



HD BRUSHLESS

1400-40241,-D
24 Volts 550 Amps

Designed to be used with:



DelStar®
SERIES 400



*Sold separately
Please contact your **MASTERVOLT** dealer



with optional air intake cover

PRODUCT SPECIFICATIONS

Part number	1400-40241
System Voltage	24V
Rated Output	550A
Output @ 2000 rpm	345A
Ground	Isolated
Mounting	Cradle
Rotation	Bidirectional
Temperature limits:	Low -40°C / -40°F
	High 93°C / 200°F
	High 110°C / 230°F (with fresh air intake hose)
Speed limits:	7000 RPM continuous
	8000 RPM intermittent
Coating	Corrosion-Resistant E-Coated
Weight	94 Lbs / 42.5 Kg.
Regulator	<i>Alpha Pro III</i> (Remote)

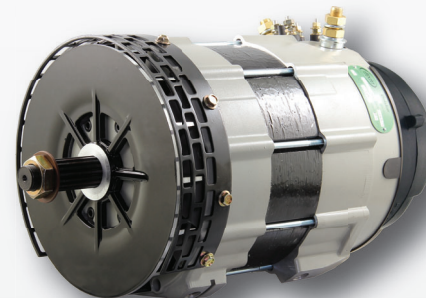

1400-40241-D
with optional air precleaner

RECOMMENDED FOR:

- Coach & Transit Busses
- Marine
- Mining
- Construction
- Industrial

ACCESSORIES:

- Air Precleaner # 4800-2101

NOTE:

This DelStar 1400-40241 alternator, meets the marine requirements for Ignition Protection on gas or diesel engines of ISO 8846, USCG, stated in Title 33 CFR 183.410, SAE J1171 and International CE Standards.

ALTERNATORS

DelStar®

SERIES 400

OUTLINE

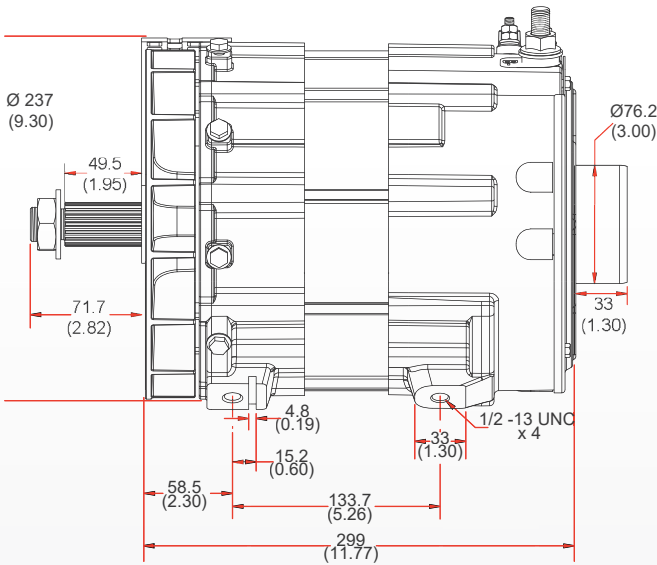

Dimensions are listed in mm over (in)

PERFORMANCE CURVES

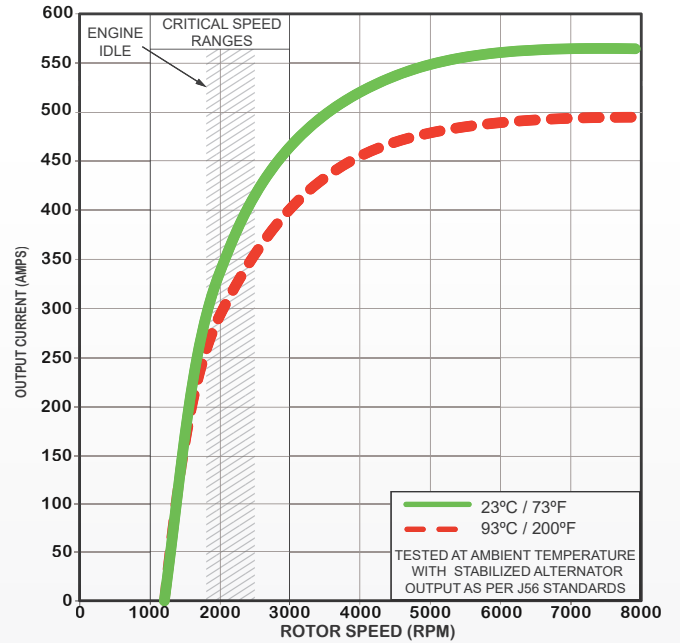

1400-40241
24 Volts, 550 Amps

CONNECTIONS

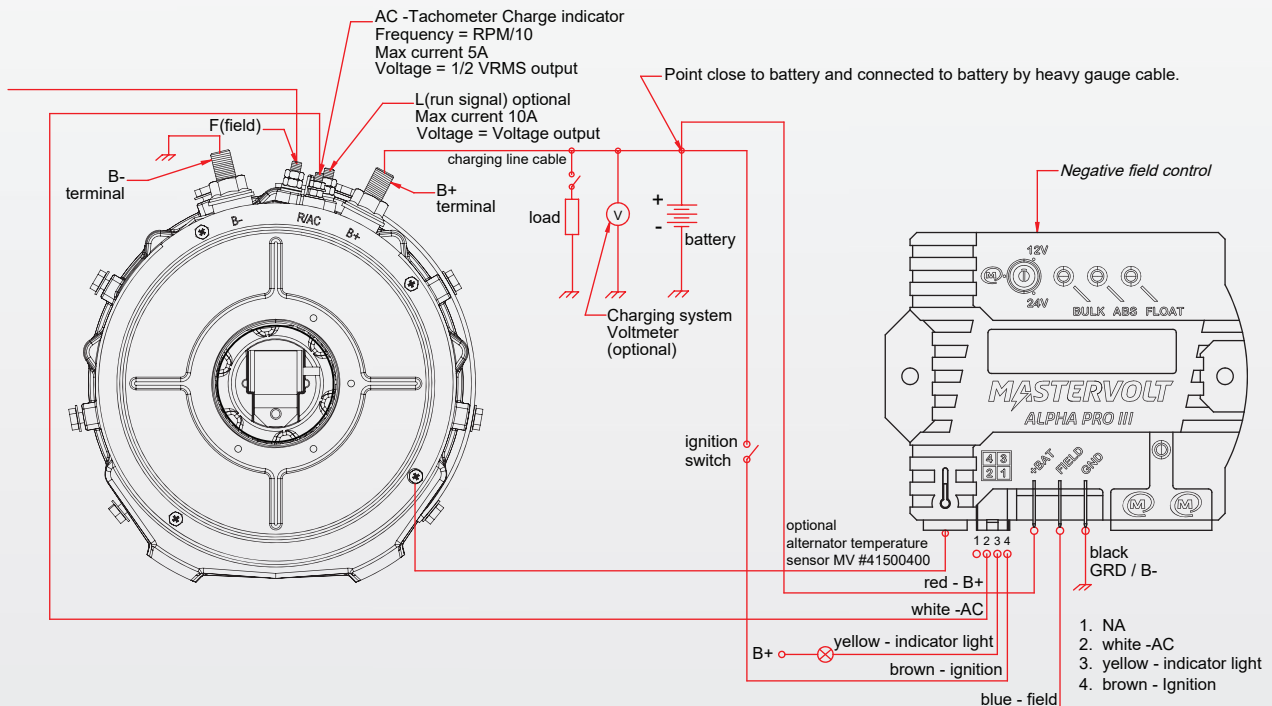

CANADA & EXPORT SALES

Dixie Electric
517 Basaltic Road
Concord, ON
Canada L4K 4W8

Tel: 905-879-0533 | 800-461-5799
Fax: 905-879-0532
E-Mail: sales@dixie-electric.com
www.dixie-electric.com



U.S.A. SALES

Dixie Electric Inc.
5600 Pioneer Creek Drive, Suite D
Maple Plain, MN 55359
U.S.A.

Tel: 763-475-6629 | 800-478-0608
Fax: 763-475-6635 | 800-392-8719
E-Mail: mn.sales@dixie-electric.com
www.dixie-electric.us