

100-252011,-D

28 Volts 320 Amps

PRODUCT SPECIFICATIONS

Part number	100-252011
System Voltage	24V
Rated Output	320A
Outout @ 2000 rpm	215A
Ground	Negative
Mounting	7" Custom Hinge
Rotation	Bidirectional
Temperature limits:	
Low	- 40°C / -40°F
High	110°C / 230°F
High	125°C / 257°F (with fresh air intake)
Speed limits:	7000 RPM continuous 8000 RPM intermittent
Pulley	8 Groves, Ø 80.5mm
Coating	Corrosion-Resistant E-Coated
Weight	61.7 Lbs / 28 Kg.
Regulator	Integral
Indicator Light	Yes
Remote Sense	Yes
Soft Start Delay (SSD)	Yes
Load Response Control (LRC)	Yes
Field Short Circuit Protection	Yes
Load Dump Protection	Yes
Overvoltage Shut-Down (OSD)	Yes

ACCESSORIES:

90° Elbow Pkg. (360° Rotatable) # 46900-1800

RECOMMENDED FOR:

- Coach & Transit Busses
- Marine
- Mining
- Construction, Industrial



100-252011



100-252011-D

with air intake cover & Optional 90° elbow

NOTE:

This DelStar 100-252011 alternator, meets the marine requirements for Ignition Protection on gas or diesel engines of ISO 8846, USCG, stated in Title 33 CFR 183.410, SAE J1171 and International CE Standards.

PERFORMANCE CURVES

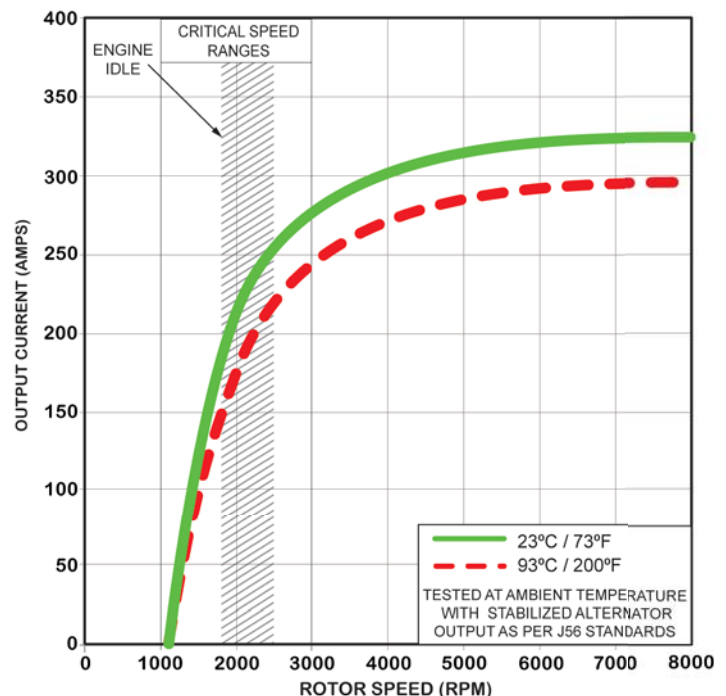

OUTLINE

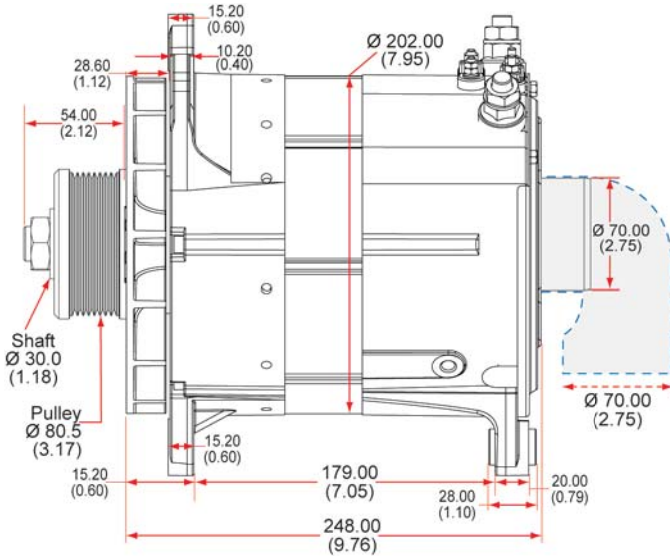

CONNECTIONS

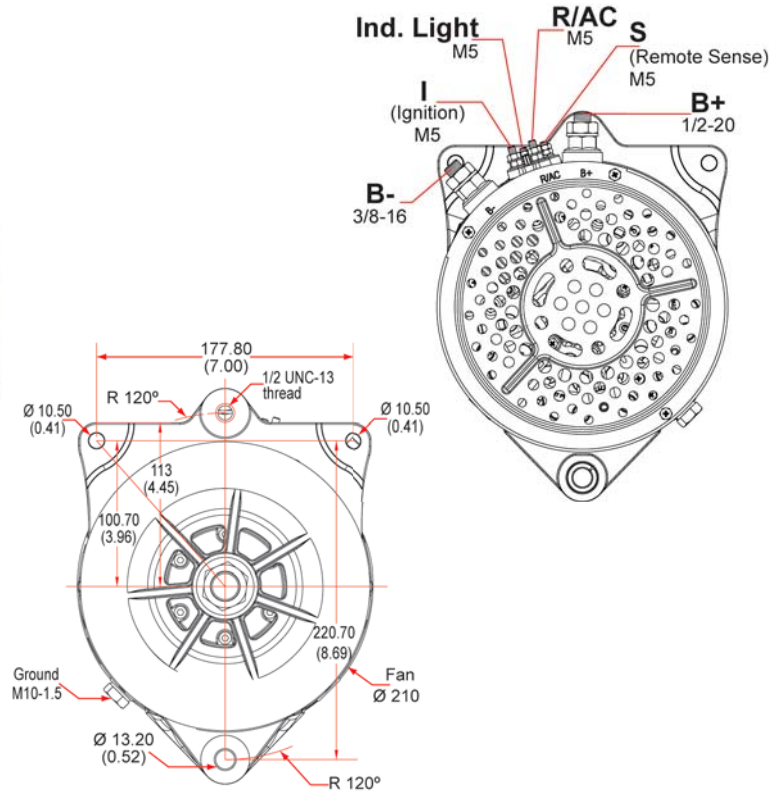

100-252011,-D
28 Volts 320 Amps

ELECTRICAL SCHEMATIC

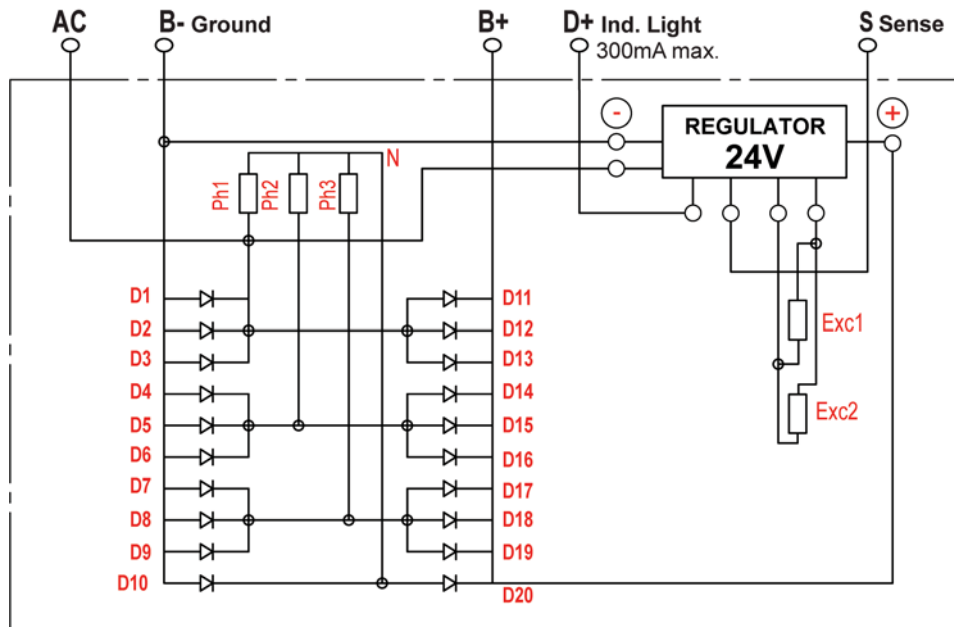

D100-252011 - 170830 - Rev. 190801

CANADA & EXPORT SALES

Dixie Electric Ltd.
517 Basaltic Road
Concord, ON.
Canada L4K 4W8
Tel.: 905-879-0533 800-461-5799
Fax: 905-879-0532
E-Mail: sales@dixie-electric.com
Web Site: www.dixie-electric.com
www.delstar-hd.com



U.S.A. SALES

Dixie Electric Inc.
17100 Medina Rd, Suite 100
Minneapolis, MN.
U.S.A. 55447-1249

Tel.: 763-475-6629 800-478-0608
Fax: 763-475-6635 800-392-8719
E-Mail: mn.sales@dixie-electric.com
Web Site: www.dixie-electric.us