

100-17209,-D 28 Volts 175 Amps

PRODUCT SPECIFICATIONS

Part number	100-17209
System Voltage	24V
Rated Output	175A
Output @ 2000 rpm	70A
Ground	Isolated
Mounting	J180 4"Hinge
Rotation	Bidirectional
Temperature limits:	
Low	-40°C / -40°F
High	125°C / 257°F
Speed limits:	
	8000 RPM continuous
	9000 RPM intermittent
Coating	Corrosion-Resistant E-Coated
Weight	38 Lbs / 17.4 Kg.
Regulator	Integral
Excitation	Self-excited
Indicator Light	Yes
Remote Sense	Yes
Soft Start Delay (SSD)	Yes
Field Short Circuit Protection	Yes
Load Dump Protection	Yes
Overvoltage Shut-Down (OSD)	Yes

RECOMMENDED FOR:

- Utility Vehicles
- Marine, Mining
- Industrial
- Construction



100-17209



100-17209-D

with air intake cover

NOTE:

This DelStar 100-17209 alternator, meets the marine requirements for Ignition Protection on gas or diesel engines of ISO 8846, USCG, stated in Title 33 CFR 183.410, SAE J1171 and International CE Standards.

PERFORMANCE CURVES

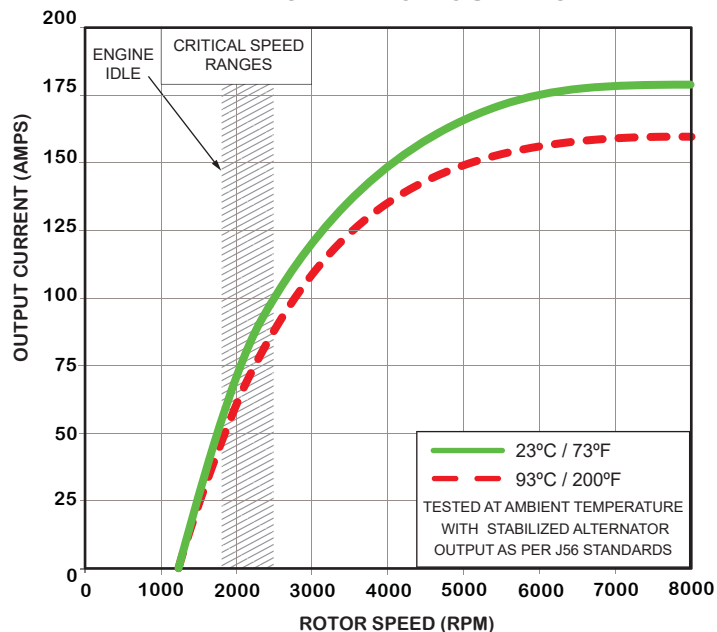

OUTLINE

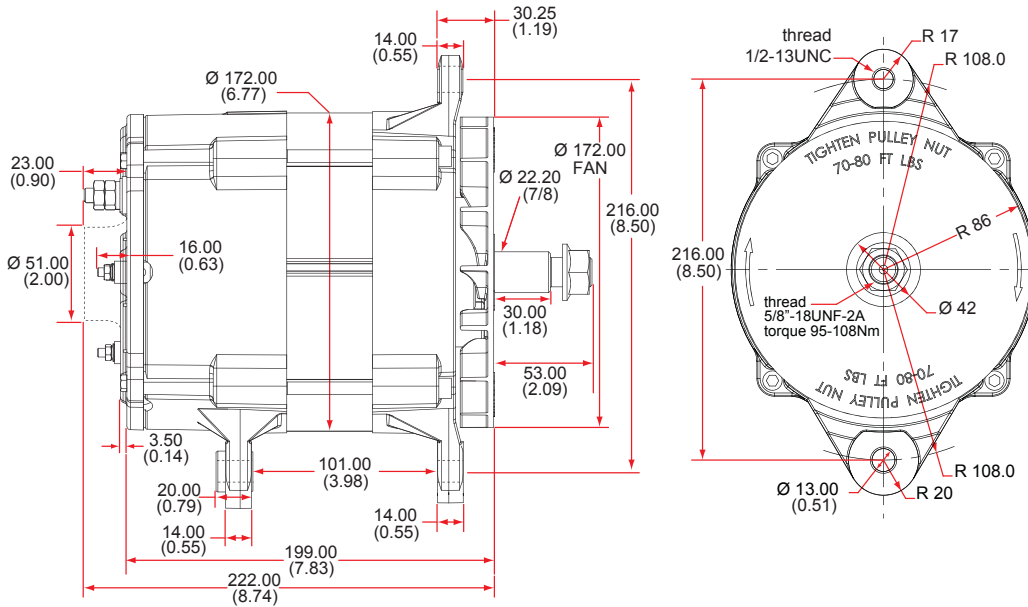

CONNECTIONS

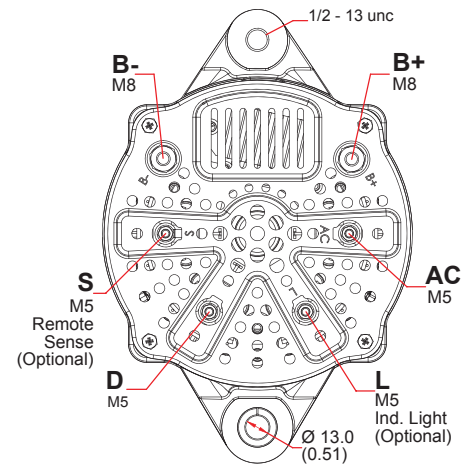

Dimensions are listed in mm over (in)

100-17209

28 Volts 175 Amps

ELECTRICAL SCHEMATIC

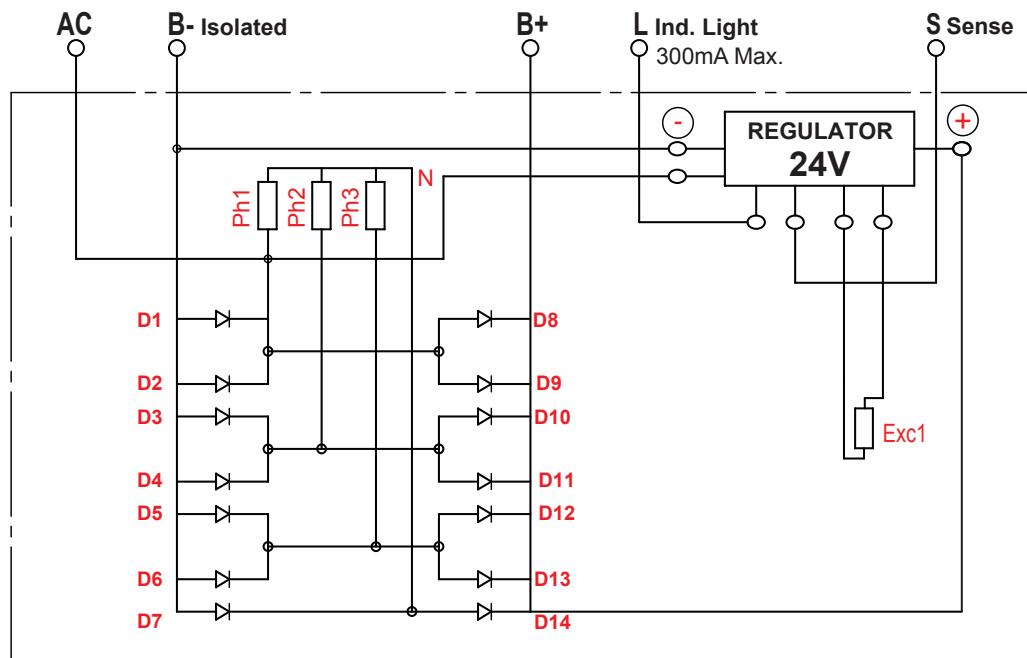

D100-17209 - 150616 - Rev. 190219

CANADA

Dixie Electric Ltd.
517 Basaltic Road
Concord, ON.
Canada L4K 4W8

Tel.: 905-879-0533 800-461-5799
Fax: 905-879-0532
E-Mail: sales@dixie-electric.com
Web Site: www.dixie-electric.com



U.S.A.

Dixie Electric Inc.
5600 Pioneer Creek Drive, Suite D
Maple Plain, MN 55359
U.S.A.

Tel.: 763-475-6629 800-478-0608
Fax: 763-475-6635 800-392-8719
E-Mail: mn.sales@dixie-electric.com
Web Site: www.dixie-electric.us