

# 100-41210

## 28 Volts 525 Amps

### PRODUCT SPECIFICATIONS

Part number	100-41210
System Voltage	24V
Rated Output	525A
Output @ 2000 rpm	335A
Ground	Negative
Mounting	Cradle
Rotation	Bidirectional
Temperature limits:	
Low	-40°C / -40°F
High	93°C / 200°F (with air precleaner)
High	110°C / 230°F (with fresh air intake hose)

Speed limits:	7000 RPM continuous 8000 RPM intermittent
Coating	Corrosion-Resistant E-Coated
Weight	94 Lbs / 42.5 Kg.
Regulator	Internal
Excitation	IGN-Excite

Indicator Light	Yes
Remote Sense	Yes
Soft Start Delay (SSD)	Yes
Load Response Control (LRC)	Yes
Field Short Circuit Protection	Yes
Load Dump Protection	Yes
Overvoltage Shut-Down (OSD)	Yes

#### ACCESSORIES:

Air Precleaner	# 4800-2101
Oil Line Cap Kit (oil cooled to air cooled conversion)	# 4900-5000

#### RECOMMENDED FOR:

- Transit Bus
- Motor Coach
- Marine
- Mining
- Industrial



With Air Precleaner (as supplied)

#### NOTE:

*This DelStar 100-41210 alternator, meets the marine requirements for Ignition Protection on gas or diesel engines of ISO 8846, USCG, stated in Title 33 CFR 183.410, SAE J1171 and International CE Standards.*

#### PERFORMANCE CURVES

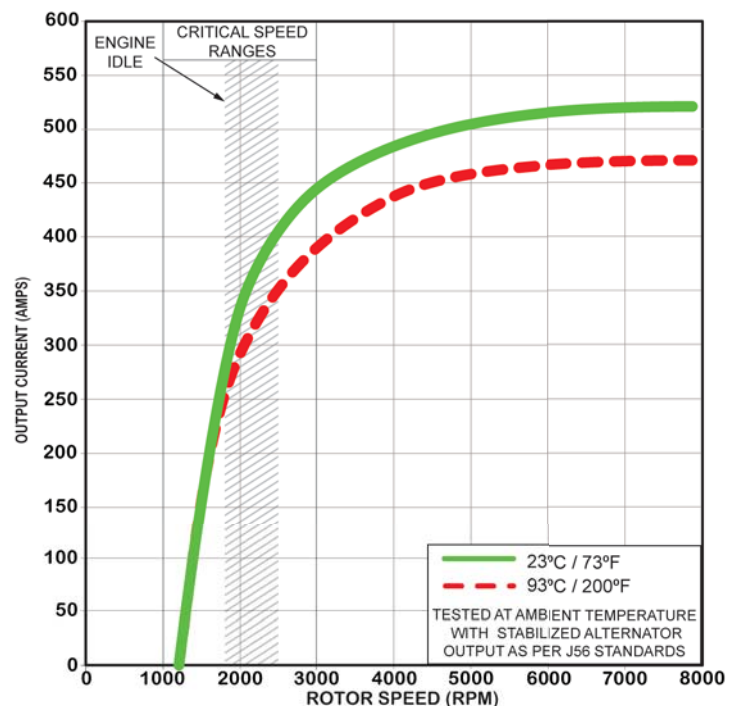

### OUTLINE

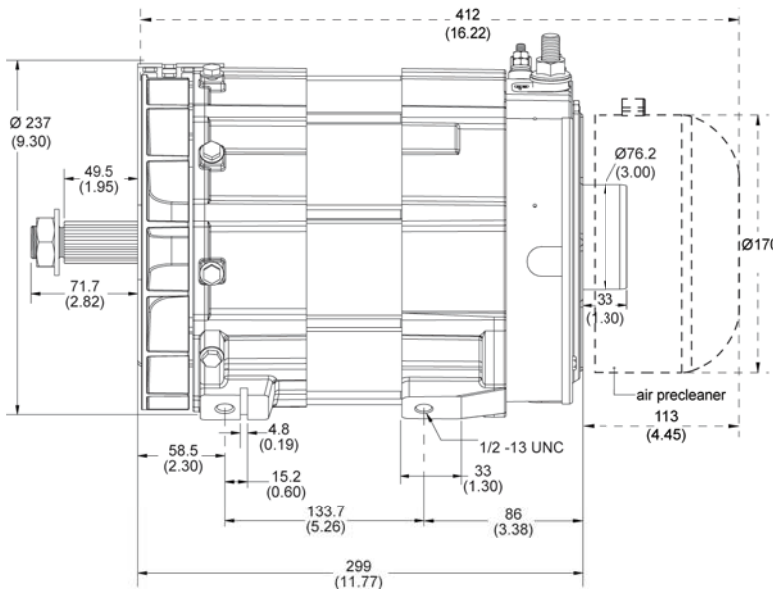

### CONNECTIONS

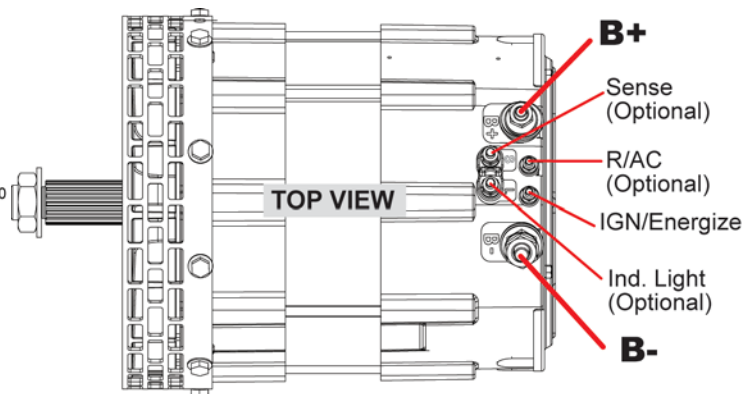

Dimensions are listed in mm over (in)

100-41210  
28 Volts 525 Amps

### ELECTRICAL SCHEMATIC

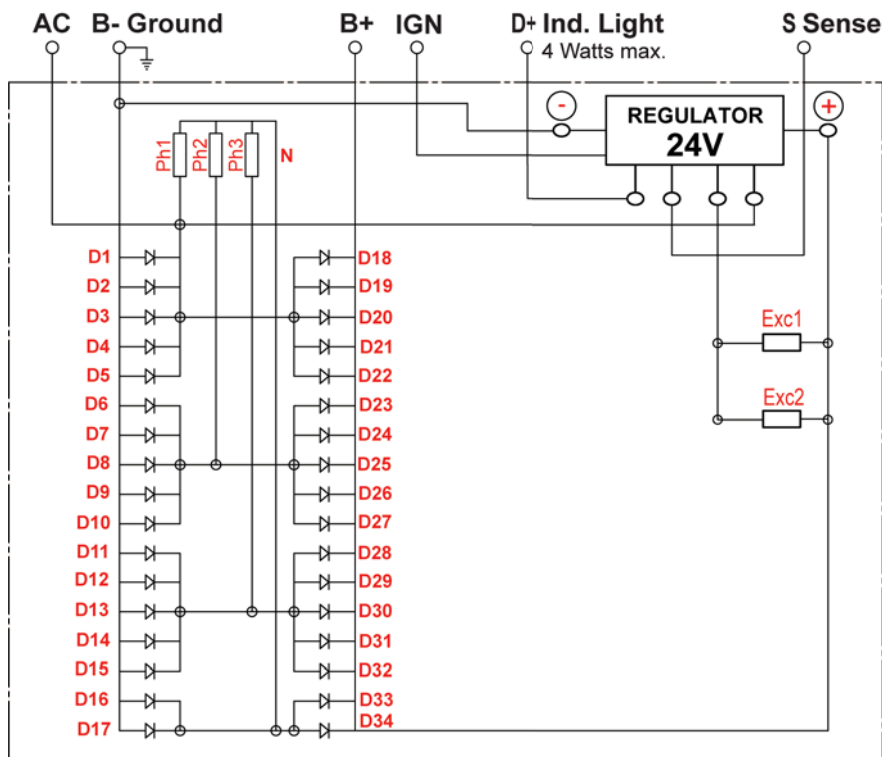

#### CANADA & EXPORT SALES

Dixie Electric Ltd.  
517 Basaltic Road  
Concord, ON.  
Canada L4K 4W8  
Tel.: 905-879-0533 800-461-5799  
Fax: 905-879-0532  
E-Mail: sales@dixie-electric.com  
Web Site: www.dixie-electric.com



#### U.S.A. SALES

Dixie Electric Inc.  
17100 Medina Rd, Suite 100  
Minneapolis, MN.  
U.S.A. 55447-1249  
Tel.: 763-475-6629 800-478-0608  
Fax: 763-475-6635 800-392-8719  
E-Mail: mn.sales@dixie-electric.com  
Web Site: www.dixie-electric.com