

# 100-40218

## 28 Volts 550 Amps

### PRODUCT SPECIFICATIONS

Part number	100-40218
System Voltage	24V
Rated Output	550A
Output @ 2000 rpm	320A
Ground	Isolated
Noise Suppression	Built-in (SAE-J1908 Standard)
Mounting	Cradle
Rotation	Bidirectional
Temperature limits:	
Low	- 40°C / -40°F
High	110°C / 230°F (with fresh air intake hose)
Speed limits:	
7000 RPM continuous	
8000 RPM intermittent	
Coating	Corrosion-Resistant E-Coated
Weight	94 Lbs / 42.5 Kg.
Regulator	Remote
Relay/AC	M5 terminal
L /Run (Signal)	M6 terminal

#### ACCESSORIES:

8-Groove Clutch Pulley	# 2400-4000
Remote Voltage Regulator	# 3500-50251

#### RECOMMENDED FOR:

- Transit Bus
- Motor Coach
- Marine
- Mining
- Industrial



#### NOTE:

*This DelStar 100-40218 alternator, meets the marine requirements for Ignition Protection on gas or diesel engines of ISO 8846, USCG, stated in Title 33 CFR 183.410, SAE J1171 and International CE Standards.*

#### PERFORMANCE CURVES

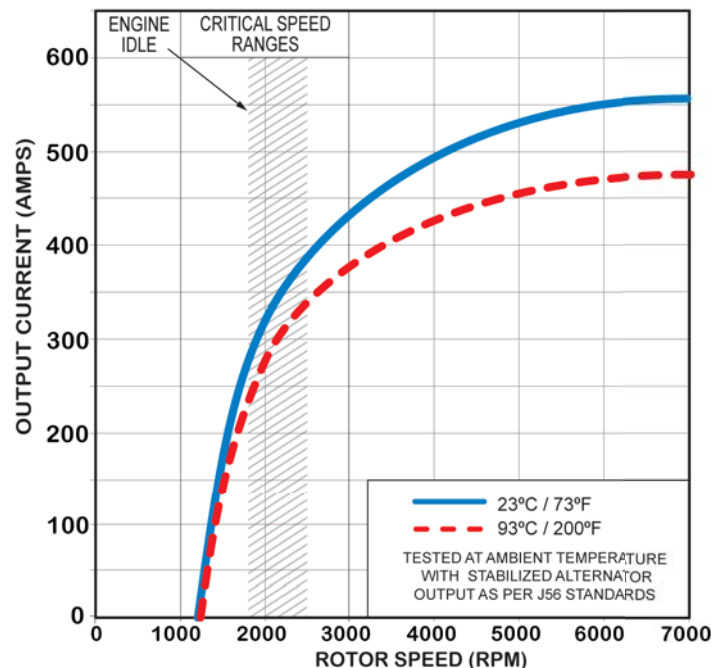

### OUTLINE

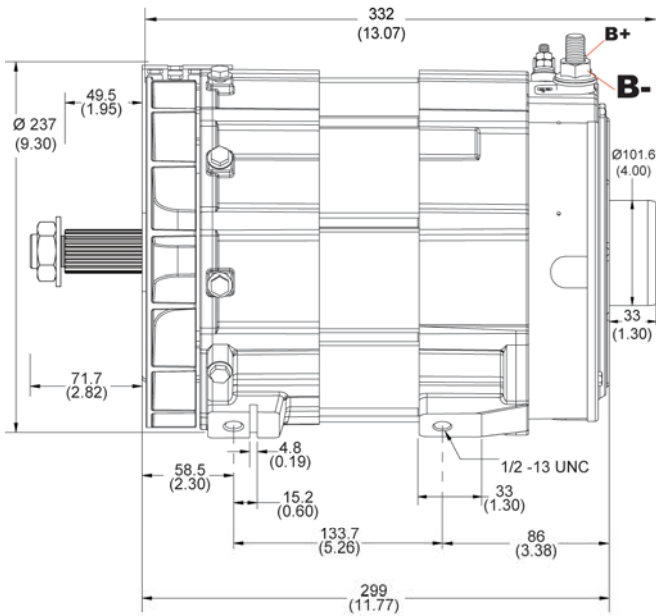

Dimensions are listed in mm over (in)

## 100-40218

## 28 Volts 550 Amps

### CONNECTIONS

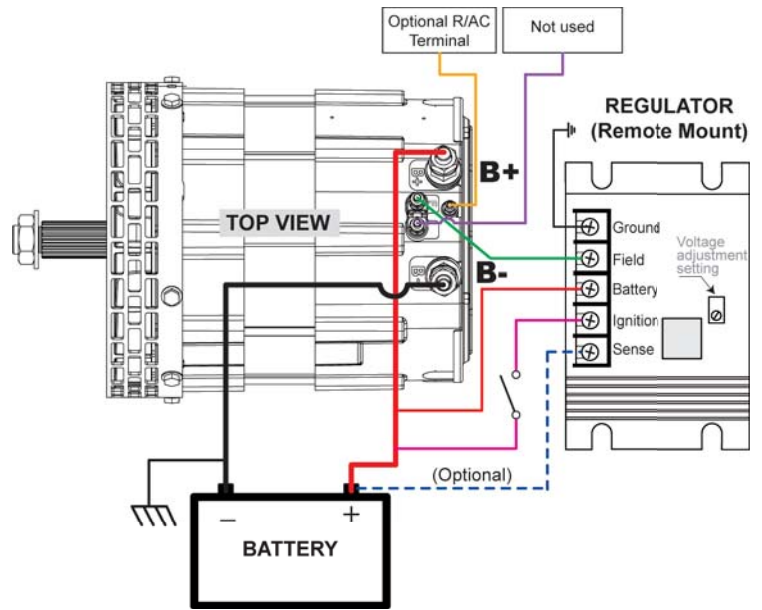

### ELECTRICAL SCHEMATIC

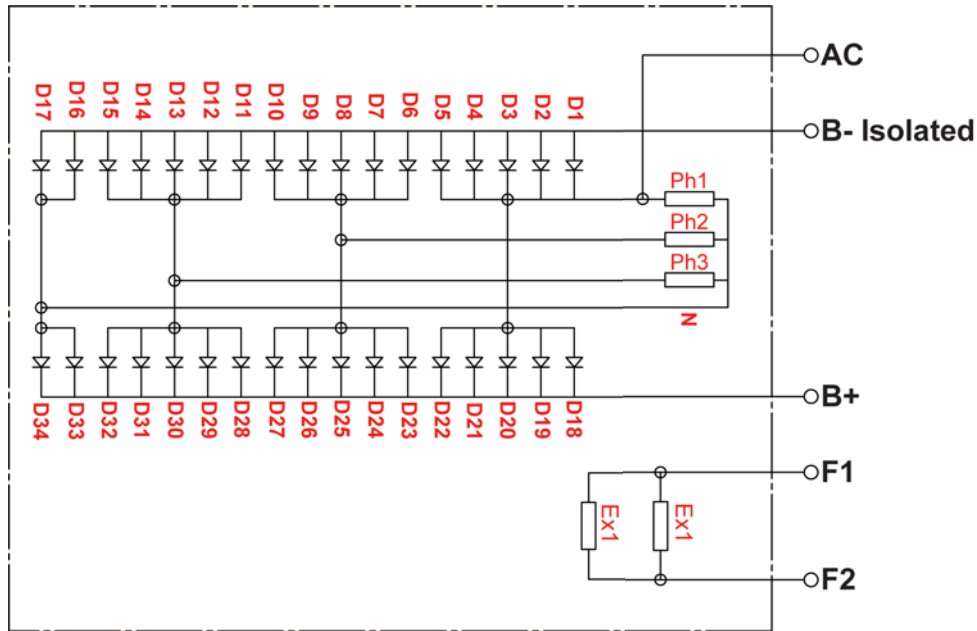

#### CANADA & EXPORT SALES

Dixie Electric Ltd.  
517 Basaltic Road  
Concord, ON.  
Canada L4K 4W8  
Tel.: 905-879-0533 800-461-5799  
Fax: 905-879-0532  
E-Mail: sales@dixie-electric.com  
Web Site: www.dixie-electric.com  
www.delstar-hd.com



#### U.S.A. SALES

Dixie Electric Inc.  
17100 Medina Rd, Suite 100  
Minneapolis, MN.  
U.S.A. 55447-1249

Tel.: 763-475-6629 800-478-0608  
Fax: 763-475-6635 800-392-8719  
E-Mail: mn.sales@dixie-electric.com  
Web Site: www.dixie-electric.us