

100-30212

28 Volts 400 Amps

PRODUCT SPECIFICATIONS

Part number	100-30212
System Voltage	24V
Rated Output	400A
Output @ 2000 rpm	260A
B+ Terminal	@ 1:00 o'clock, viewed from pulley side
Ground	Negative
Mounting	Cradle
Rotation	Bidirectional
Temperature limits:	
Low	- 40°C / -40°F
High	93°C / 200°F (with air precleaner)
High	110°C / 230°F (with fresh air intake hose)
Speed limits:	7000 RPM continuous 8000 RPM intermittent
Coating	Corrosion-Resistant E-Coated
Weight	77 Lbs / 35 Kg.
Regulator	Remote
Relay/AC	M5 terminal
L /Run (Signal)	M6 terminal

ACCESSORIES:

Remote Voltage Regulator	# 3500-50251
Air Precleaner	# 4800-2101
Oil Line Cap Kit	# 4900-5000
(oil cooled to air cooled conversion)	

RECOMMENDED FOR:

- Transit Bus
- Motor Coach
- Marine
- Mining
- Industrial



NOTE: With Air Precleaner (as supplied)

This DelStar 100-30212 alternator, meets the marine requirements for Ignition Protection on gas or diesel engines of ISO 8846, USCG, stated in Title 33 CFR 183.410, SAE J1171 and International CE Standards.

PERFORMANCE CURVES

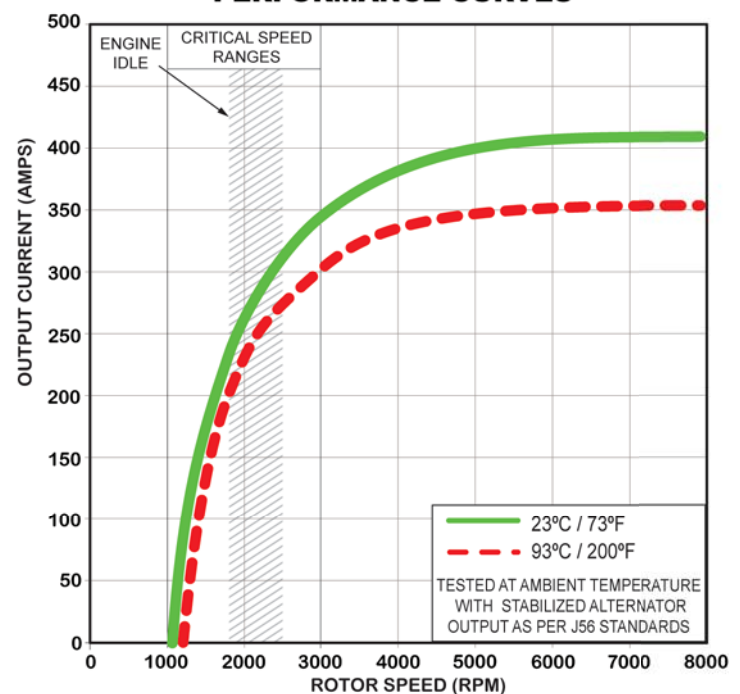

OUTLINE

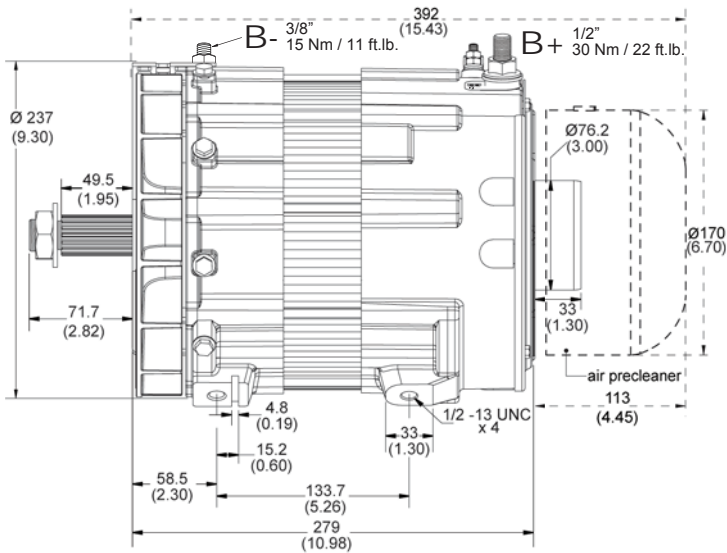

Dimensions are listed in mm over (in)

CONNECTIONS

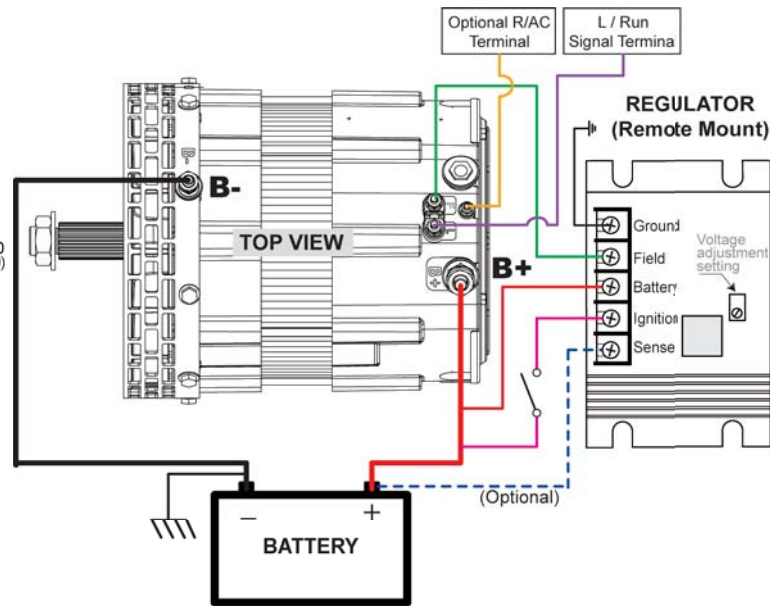

100-30212

28 Volts 400 Amps

ELECTRICAL SCHEMATIC

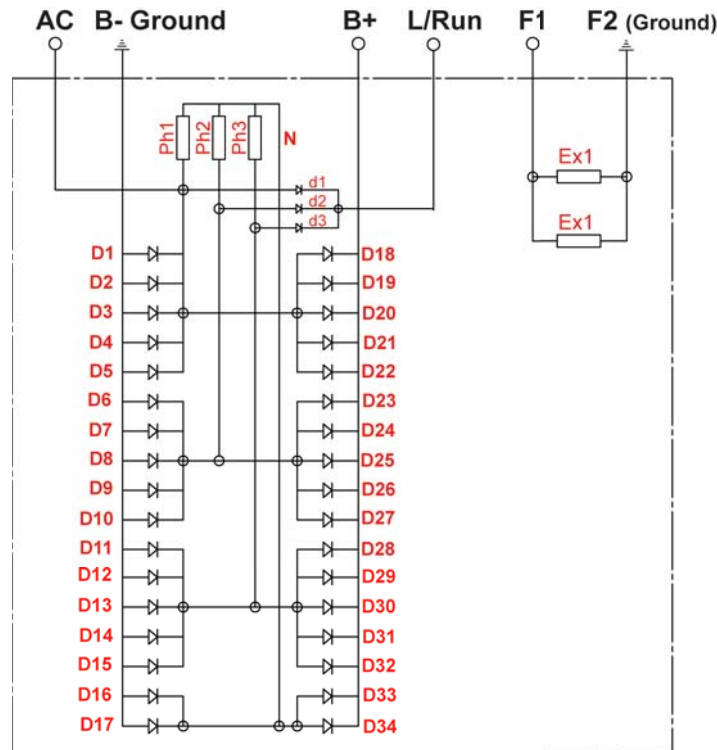

CANADA & EXPORT SALES

Dixie Electric Ltd. Tel.: 905-879-0533 800-461-5799
 517 Basaltic Road Fax: 905-879-0532
 Concord, ON. E-Mail: sales@dixie-electric.com
 Canada L4K 4W8 Web Site: www.dixie-electric.com



U.S.A. SALES

Dixie Electric Inc.
 17100 Medina Rd, Suite 100
 Minneapolis, MN.
 U.S.A. 55447-1249

Tel.: 763-475-6629 800-478-0608
 Fax: 763-475-6635 800-392-8719
 E-Mail: mn.sales@dixie-electric.com
 Web Site: www.dixie-electric.com