

### 100-252021,-D 28 Volts 320 Amps

#### PRODUCT SPECIFICATIONS

<b>Part number</b>	100-252021
<b>System Voltage</b>	24V
<b>Rated Output</b>	320A
<b>Outout @ 2000 rpm</b>	215A
<b>Ground</b>	Negative
<b>Mounting</b>	Custom Flange
<b>Rotation</b>	Bidirectional
<b>Temperature limits:</b>	
Low	- 40°C / -40°F
High	110°C / 230°F
High	125°C / 257°F (with fresh air intake)
<b>Speed limits:</b>	
	7000 RPM continuous
	8000 RPM intermittent
<b>Pulley</b>	8 Groves, Ø 95.8mm
<b>Coating</b>	Corrosion-Resistant E-Coated
<b>Weight</b>	61.7 Lbs / 28 Kg.
<b>Regulator</b>	Integral
<b>Indicator Light</b>	Yes
<b>Remote Sense</b>	Yes
<b>Soft Start Delay (SSD)</b>	Yes
<b>Load Response Control (LRC)</b>	Yes
<b>Field Short Circuit Protection</b>	Yes
<b>Load Dump Protection</b>	Yes
<b>Overvoltage Shut-Down (OSD)</b>	Yes

#### ACCESSORIES:

**90° Elbow Pkg.** (360° Rotatable) # 46900-1800

#### RECOMMENDED FOR:

- Coach & Transit Busses
- Marine
- Mining
- Construction, Industrial



**100-252021**



**100-252021-D**

with air intake cover & Optional 90° elbow

#### NOTE:

*This DelStar 100-252021 alternator, meets the marine requirements for Ignition Protection on gas or diesel engines of ISO 8846, USCG, stated in Title 33 CFR 183.410, SAE J1171 and International CE Standards.*

#### PERFORMANCE CURVES

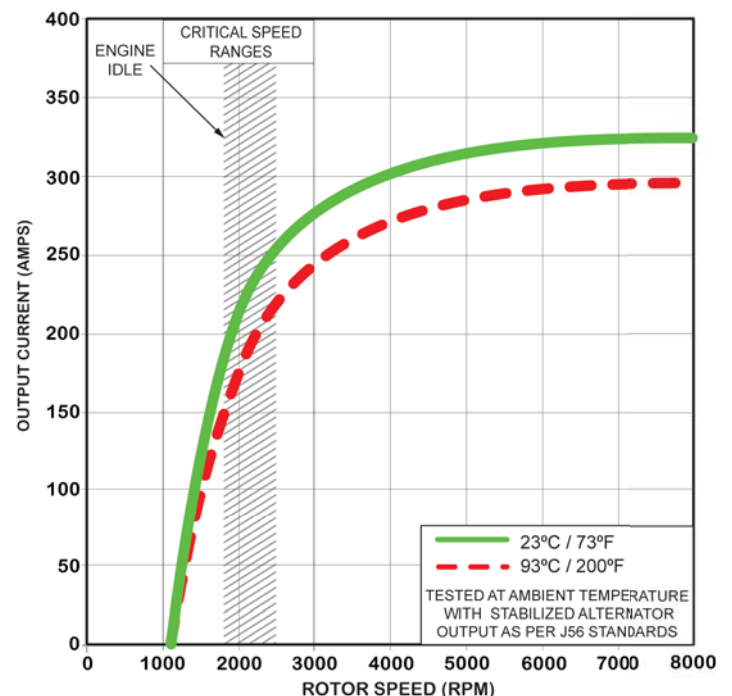

### OUTLINE

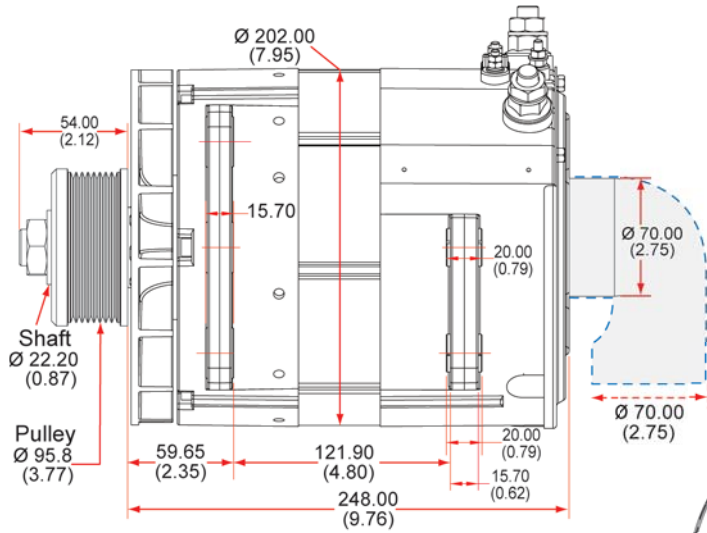

### CONNECTIONS

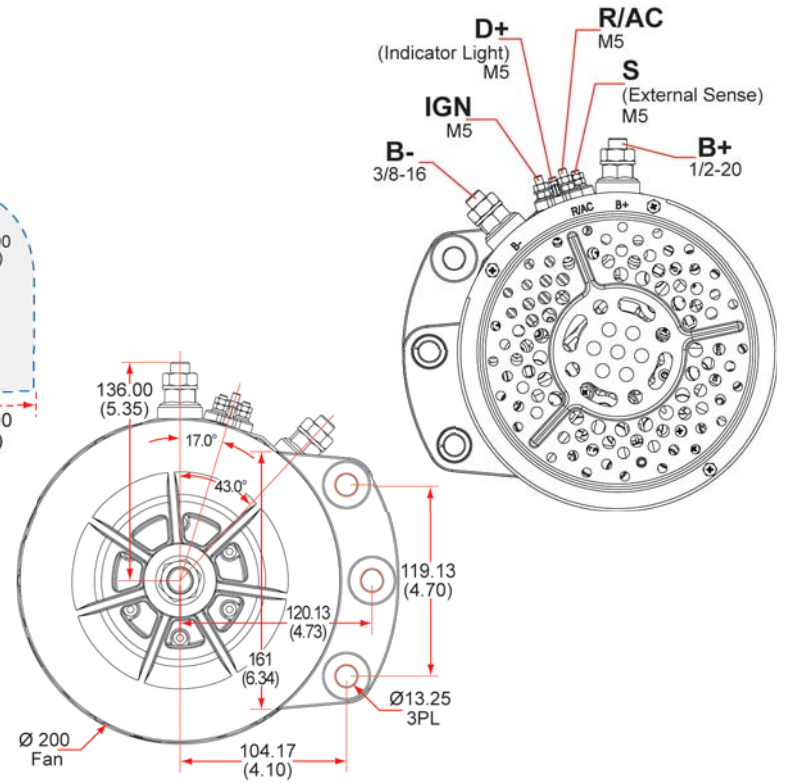

100-252021,-D  
28 Volts 320 Amps

### ELECTRICAL SCHEMATIC

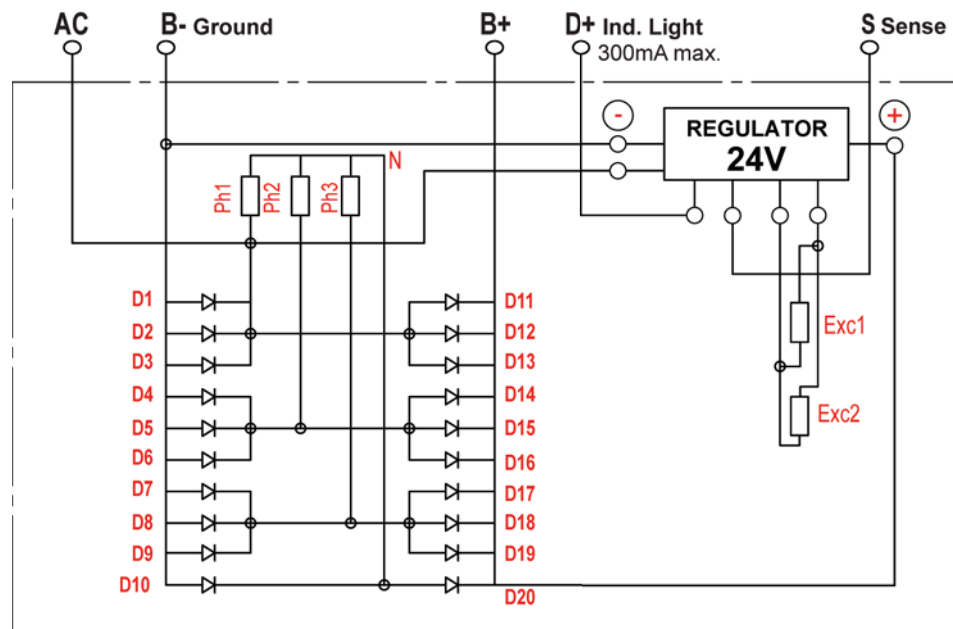

D100-252021 - 170830 - 190801

#### CANADA & EXPORT SALES

Dixie Electric Ltd.  
517 Basaltic Road  
Concord, ON.  
Canada L4K 4W8

Tel.: 905-879-0533 800-461-5799  
Fax: 905-879-0532  
E-Mail: sales@dixie-electric.com  
Web Site: www.dixie-electric.com



Setting the Standard

© 2014 Dixie Electric Limited. All rights reserved.

#### U.S.A. SALES

Dixie Electric Inc.  
5600 Pioneer Creek Drive, Suite D  
Maple Plain, MN 55359  
U.S.A.

Tel.: 763-475-6629 800-478-0608  
Fax: 763-475-6635 800-392-8719  
E-Mail: mn.sales@dixie-electric.com  
Web Site: www.dixie-electric.us