

100-16205,-D 28 Volts 150 Amps

PRODUCT SPECIFICATIONS

Part number	100-16205
System Voltage	24V
Rated Output	150A
Output @ 2000 rpm	55A
Ground	Isolated
Mounting	J180 4" Hinge
Rotation	CW
Temperature limits:	
Low	-40°C / -40°F
High	110°C / 230°F
High	125°C / 257°F (with fresh air intake)
Speed limits:	
	8000 RPM continuous
	9000 RPM intermittent
Coating	Corrosion-Resistant E-Coated
Weight	28 Lbs / 12.7 Kg.
Regulator	Integral
Excitation	Self-excite (@ 1500 rpm or less)
Indicator Light	Yes
Remote Sense Regulation	Yes
Soft Start Function	Yes
6 Sec. Load Response Control (LRC)	Yes
Field Short Circuit Protection	Yes
Load Dump Protection	Yes
Over Voltage Protection	Yes

RECOMMENDED FOR:

- Utility Vehicles
- Marine, Mining
- Industrial
- Construction



100-16205



100-16205-D
with air intake cover

NOTE:

This DelStar 100-16205 alternator, meets the marine requirements for Ignition Protection on gas or diesel engines of ISO 8846, USCG, stated in Title 33 CFR 183.410, SAE J1171 and International CE Standards.

PERFORMANCE CURVES

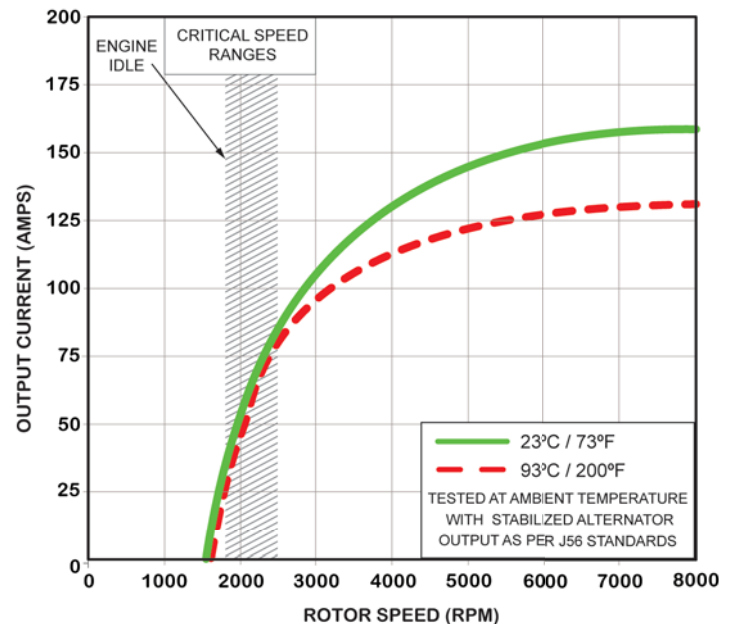

OUTLINE

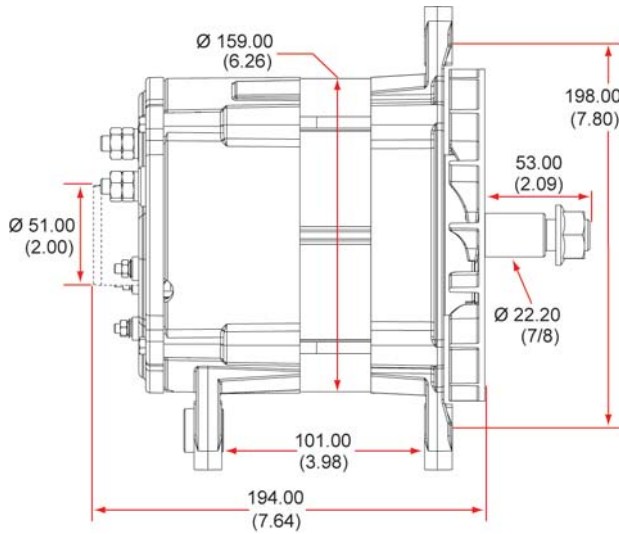

Dimensions are listed in mm over (in)

CONNECTIONS

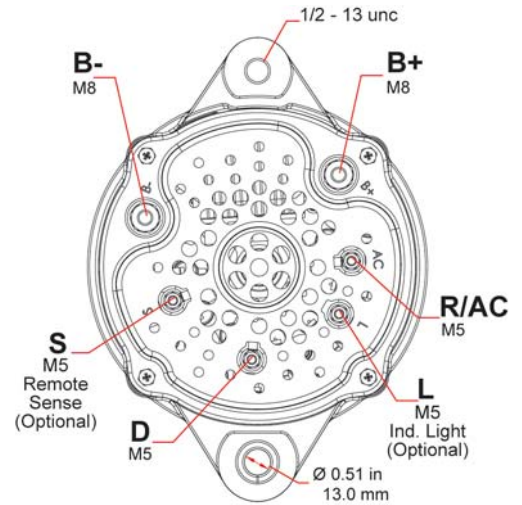

100-16205
28 Volts 150 Amps

ELECTRICAL SCHEMATIC

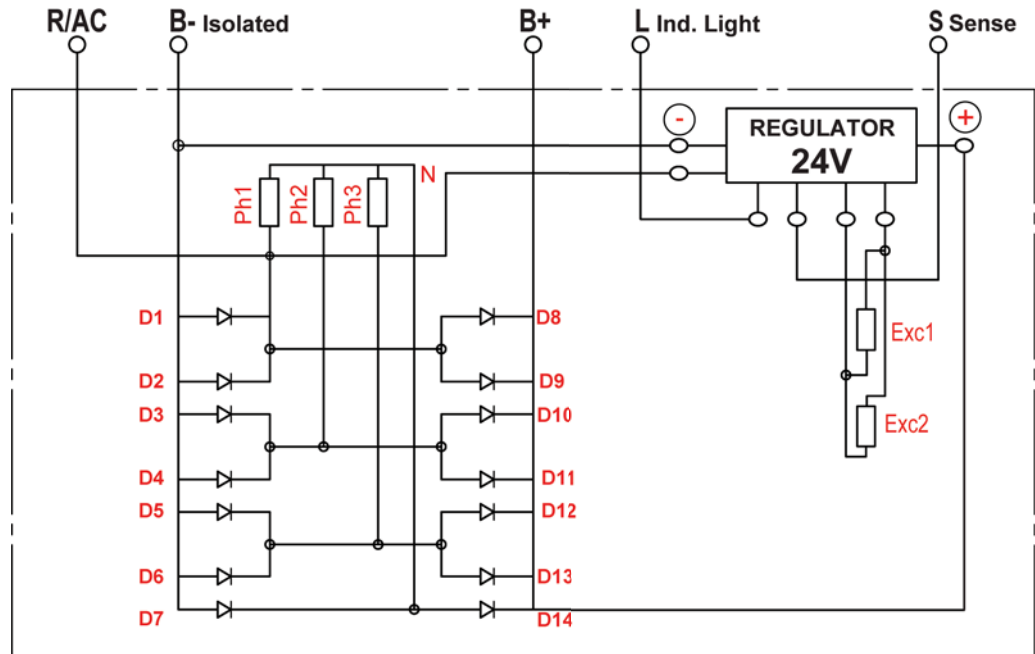

D100-16205 - 151111

CANADA & EXPORT SALES

Dixie Electric Ltd.
517 Basaltic Road
Concord, ON.
Canada L4K 4W8

Tel.: 905-879-0533 800-461-5799
Fax: 905-879-0532
E-Mail: sales@dixie-electric.com
Web Site: www.dixie-electric.com



U.S.A. SALES

Dixie Electric Inc.
17100 Medina Rd, Suite 100
Minneapolis, MN.
U.S.A. 55447-1249

Tel.: 763-475-6629 800-478-0608
Fax: 763-475-6635 800-392-8719
E-Mail: mn.sales@dixie-electric.com
Web Site: www.dixie-electric.com